

100V N-Ch Power MOSFET

V_{DS}		100	V
$R_{DS(on),typ}$	$V_{GS}=10V$	8.4	m
$R_{DS(on),typ}$	$V_{GS}=4.5V$	11.3	m
I_D (Silicon Limited)		37	A

P

P

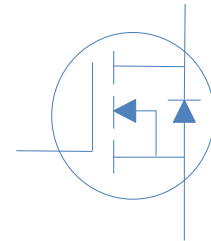

Part Number	Package	Marking
HGA098N10AL	TO-220F	GA098N10AL

Absolute Maximum Ratings at $T_J=25^{\circ}\text{C}$ (unless otherwise specified)

Parameter	Symbol	Conditions	Value	Unit
Continuous Drain Current (Silicon Limited)	I_D	$T_C=25^{\circ}\text{C}$	37	A
		$T_C=100^{\circ}\text{C}$	26	
Drain to Source Voltage	V_{DS}	-	100	V
Gate to Source Voltage	V_{GS}	-	± 20	V
Pulsed Drain Current	I_{DM}	-	140	A
Avalanche Energy, Single Pulse	E_{AS}	$L=0.1\text{mH}, T_C=25^{\circ}\text{C}$	31	mJ
Power Dissipation	P_D	$T_C=25^{\circ}\text{C}$	30	W
Operating and Storage Temperature	T_J, T_{stg}	-	-55 to 175	$^{\circ}\text{C}$

Absolute Maximum Ratings

Parameter	Symbol	Max	Unit
Thermal Resistance Junction-Ambient	R_{JA}	60	$^{\circ}\text{C}/\text{W}$
Thermal Resistance Junction-Case	R_{JC}	5	$^{\circ}\text{C}/\text{W}$



Fig 1. Typical Output Characteristics

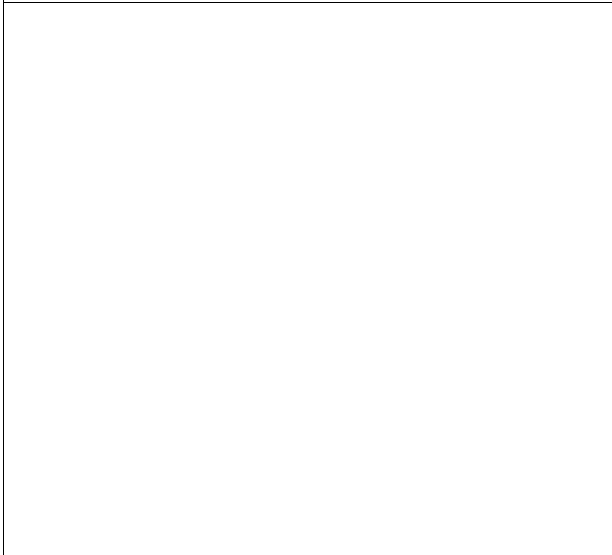

Figure 2. On-Resistance vs. Gate-Source Voltage

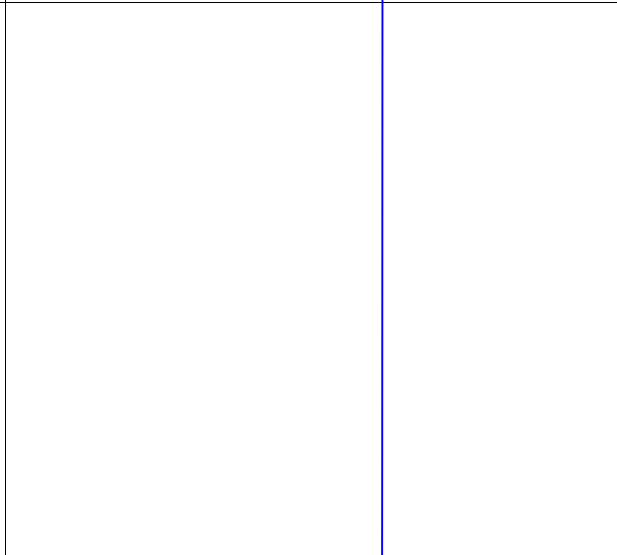

Figure 3. On-Resistance vs. Drain Current and Gate Voltage

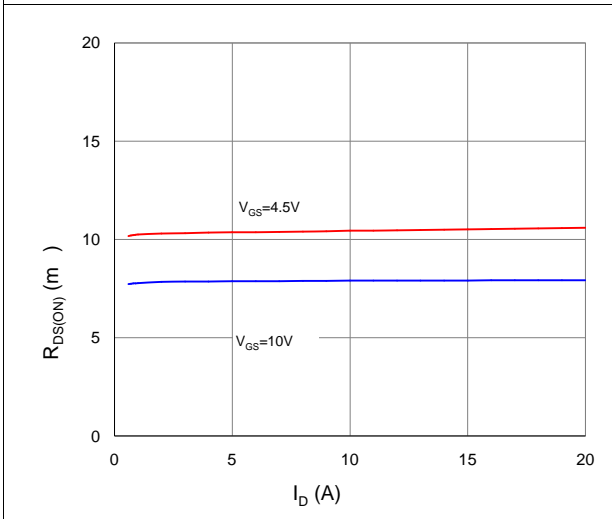

Figure 4. Normalized On-Resistance vs. Junction Temperature

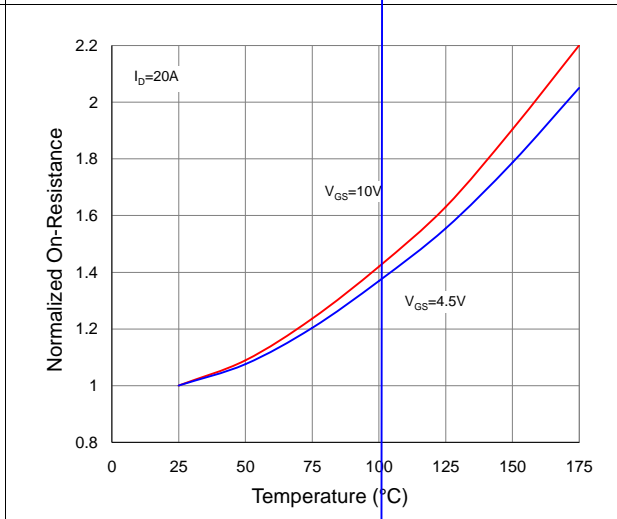

Figure 5. Typical Transfer Characteristics

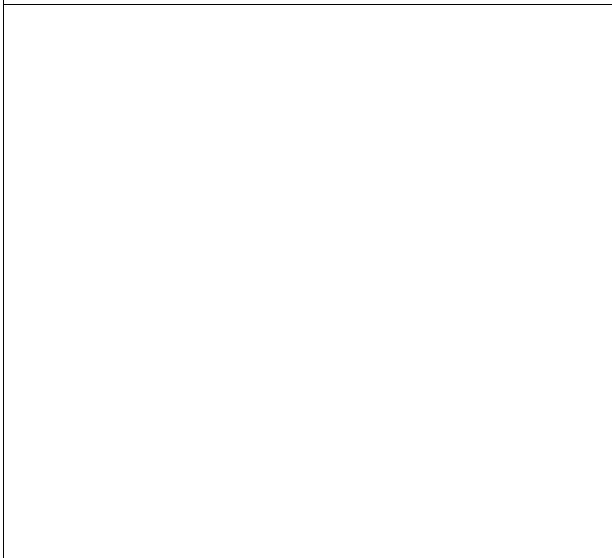

Figure 6. Typical Source-Drain Diode Forward Voltage

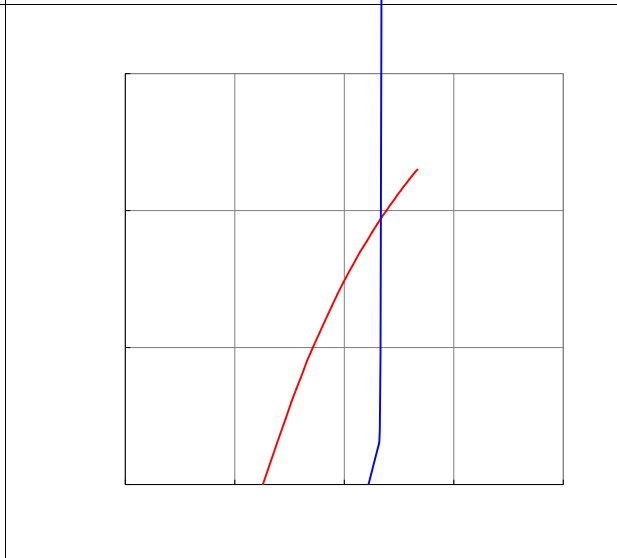

Figure 7. Typical Gate-Charge vs. Gate-to-Source Voltage

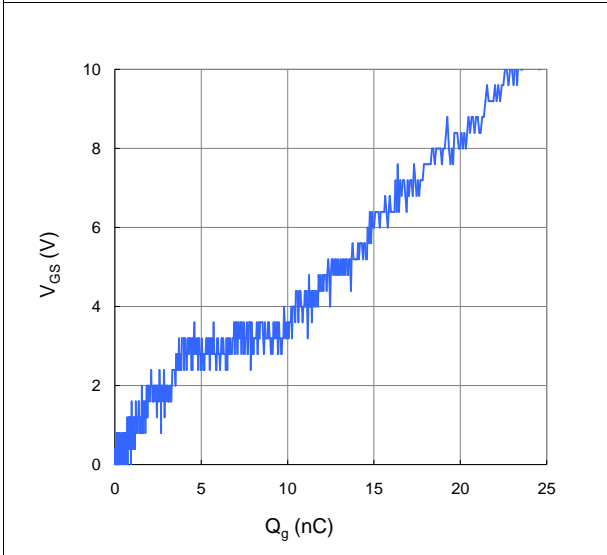

Figure 8. Typical Capacitance vs. Drain-to-Source Voltage

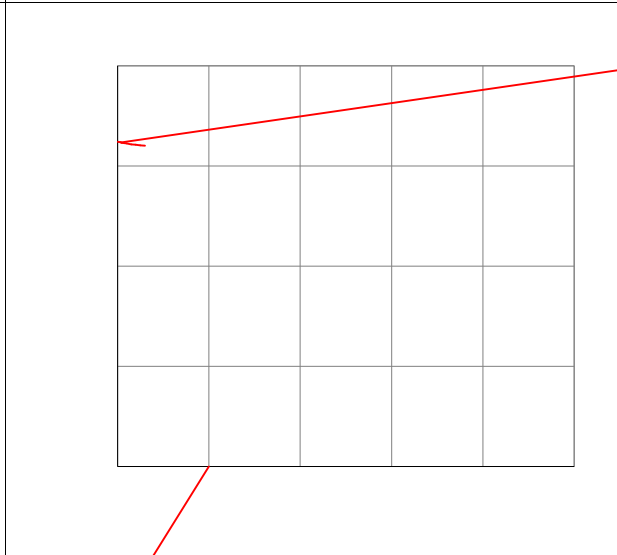

Figure 9. Maximum Safe Operating Area



Figure 10. Maximum Drain Current vs. Case Temperature



Figure 11. Normalized Maximum Transient Thermal Impedance, Junction-to-Ambient



Inductive switching Test

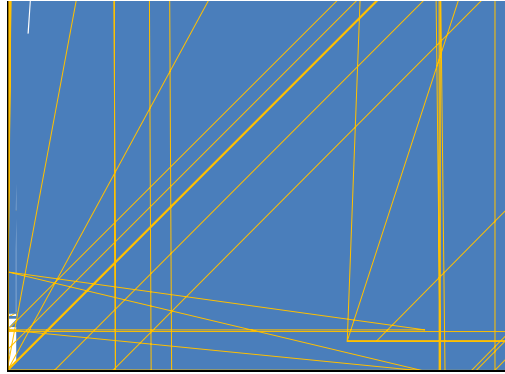

Gate Charge Test

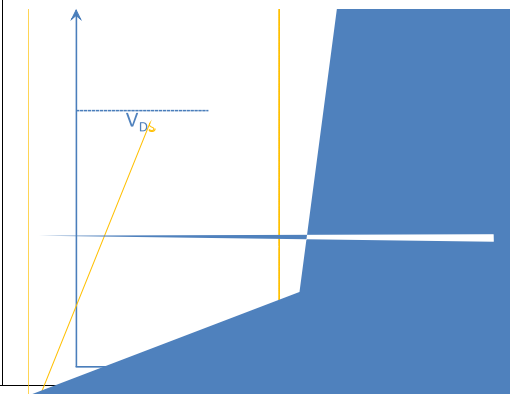

Uclamped Inductive Switching (UIS) Test

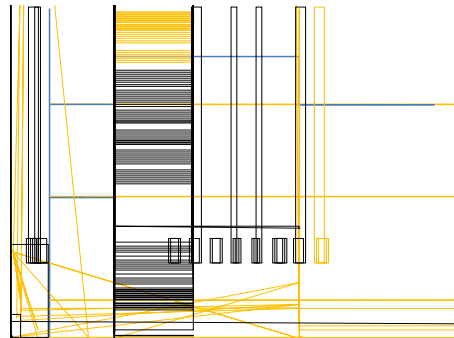
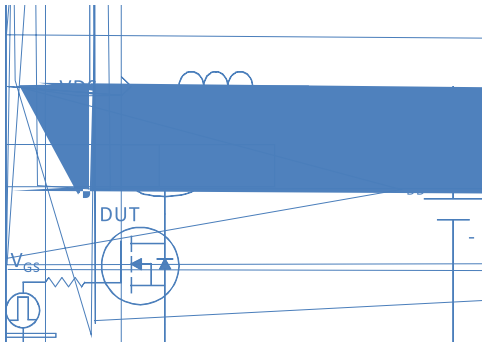

Diode Recovery Test

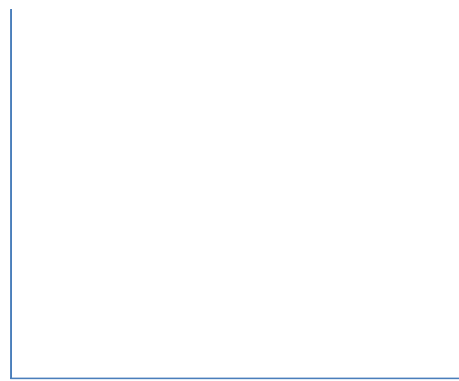
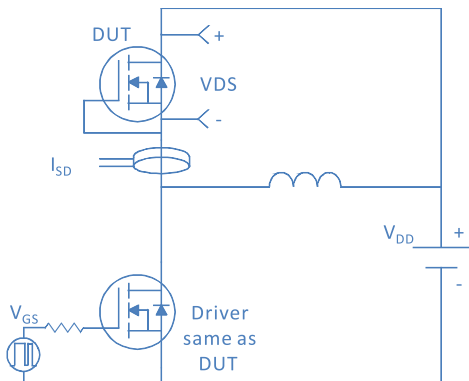

Package Outline

TO-220F, 3 leads

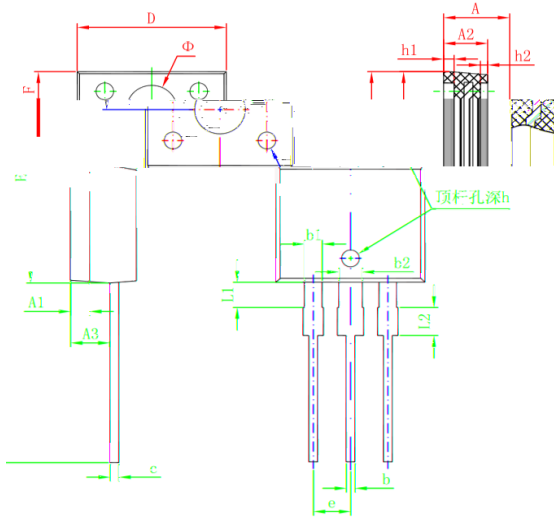

Symbol	Dimensions In Millimeters		Dimensions In Inches	
	Min.	Max.	Min.	Max.
A	4.300	4.700	0.169	0.185
A1	1.300 REF.		0.051 REF.	
A2	2.800	3.200	0.110	0.126
A3	2.500	2.900	0.098	0.113
b	0.500	0.750	0.020	0.030
b1	1.100	1.350	0.043	0.053
b2	1.500	1.750	0.059	0.069
c	0.500	0.750	0.020	0.030
D	9.500	10.300	0.374	0.406
Φ	0.000	0.000	0.000	0.000
e	2.540 TYP.		0.100 TYP.	
h	2.780 REF.		0.109 REF.	
h1	3.800 REF.		0.149 REF.	
h2	0.800	0.300	0.031	0.012
L	28.000	28.400	1.102	1.118
L1	1.790	1.900	0.070	0.075
L2	1.900	2.100	0.075	0.083

1